

CERTIFICATION



HACCP International



ISO9001

ICE MATE



SRM-650AB-14-B-801SA

ICE MAKER

HALF DICE

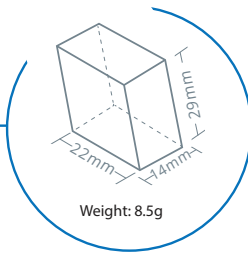

ICEMATE is committed to bringing high-efficiency / energy-saving, and high quality ice-making product to people who have dreams and desire to create their own business with the best scientific technology and manufacturing technology.

KEY FEATURES

SAFETY AND HYGIENE ASSURED ICE MACHINE

AUTO-CLEANING



Timely maintenance of water system can extend life of equipment.

PURE ICE



Overflow self-cleaning function, ensuring ice hygiene

IoT

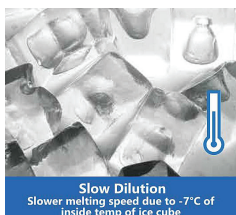

Slow melt Dilution



Powerful Ice Making



Energy & Water Saving, Quiet Operation

BIN TOP VIEW

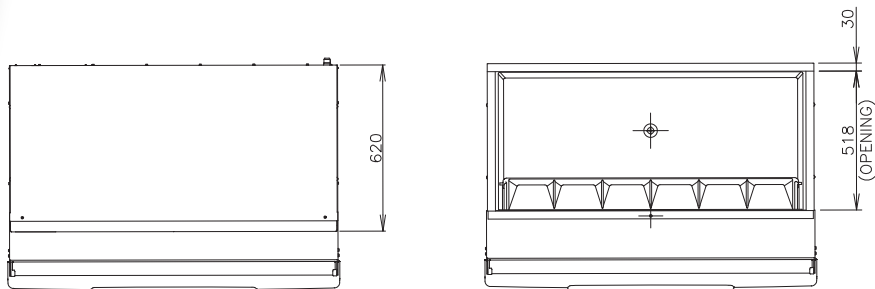

BIN TOP VIEW

FRONT SIDE

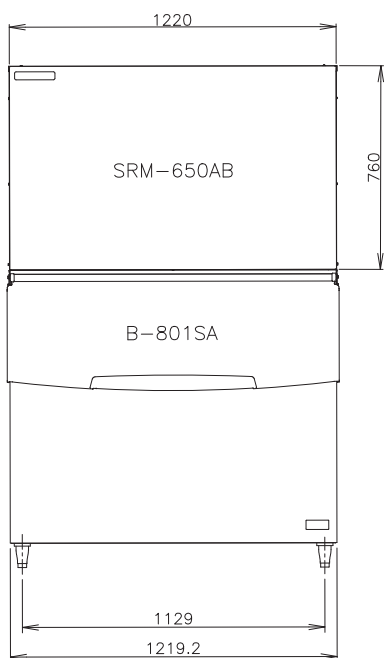

RIGHT SIDE

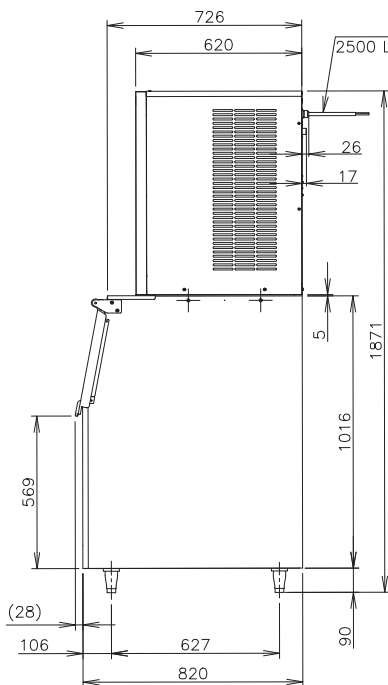

BACK SIDE

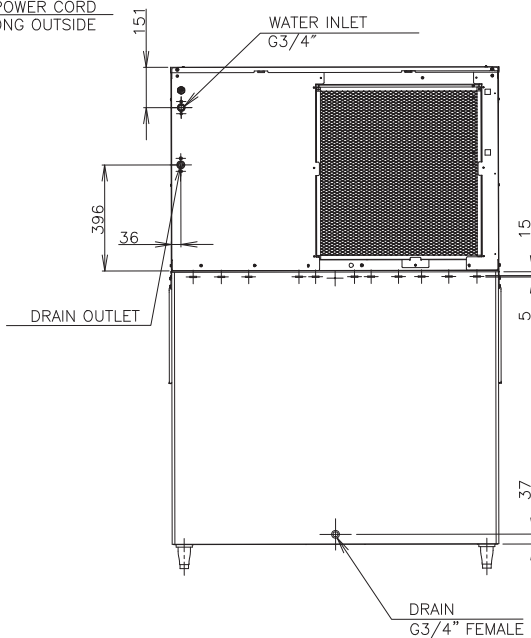

SPECIFICATIONS

Ice Dimensions	Half Dice: 29mm*14mm*22mm		Ice water consumption per 24H	(AT32°C / WT21°C)	500L(1.0L/kg ice)
Outside Dimensions	1220mm(W) x 820mm(D) x 1871(~1901)mm(H)		Ice Production Freeze Cycle Time	(AT21°C / WT15°C)	Approx:14.5min
Package Dimensions	Ice Maker: Pallet + Carton:1325mm(W) x 720mm(D) x 945mm(H) Storage Bin: Pallet + Carton:1239mm(W) x 916mm(D) x 1142mm(H)		Ice Production per Cycle	(AT21°C / WT15°C)	Approx:6.14kg/754pcs
Weight (Net / Gross)	Ice Maker:	120kg/144kg			
	Storage Bin:	64kg/86kg			
Amperage/Starting Amperage	11.4A/85A				
Electrical Consumption	(AT32°C / WT21°C)	2334W			
Refrigerant Charge	R404A/1300g				
Ice Storage Capacity	Maximum: 348kg				
Ice Production per 24H	(AT10°C / WT10°C)	Approx:690kg			
	(AT21°C / WT15°C)	Approx:607kg			
	(AT32°C / WT21°C)	Approx:492kg			
OPERATING CONDITIONS					
Voltage Range			198-242V		
Ambient Temperature			5-38°C		
Water Supply Temperature			5-32°C		
Water Supply Pressure			0.07-0.55MPa(0.7-5.5bar)		
Supply Voltage			1 Phase 220V 50Hz		



HOSHIZAKI

HOSHIZAKI (THAILAND) LIMITED

No. 99 CP Tower North Park building 9th Floor, Zone D1 Soi
Ngamwongwan 47 Intersection 42, Thung Song Hong Subdistrict, Lak Si District,
Bangkok 10210 Thailand. TEL +66 2 005 9980 | FAX +66 2 516 2646
<https://hoshizaki-sea.com>